

ALP-2300TL

1" WIDE APERTURE TRIMLESS LED PROFILE

Project _____

Location _____

Quote/ Ref # _____

The **ALP-2300TL** is an Architectural Grade, LED extrusion profile designed for recessed applications. Made from high quality aluminum, these extrusions provide superior thermal management for higher wattage LED strips prolonging the overall lifespan of the lighting system. Manufactured with a patented frosted diffuser for maximum lumen output and a wider beam distribution.



SPECIFICATIONS

TYPE	Trimless
AVAILABLE LENGTHS	48 in. 96 in.
FINISH	White
LENS OPTION	Frosted
APERTURE	1 in.
CHANNEL	ALP2300TL
LENS	ALP2300TL-LN (included)
END CAP	ALP2300TL-EC
STRAIGHT CONNECTOR	ALP2000TL-STB
INTERNAL CONNECTOR	ALP2000TL-INB
RIGHT ANGLE CONNECTOR	ALP2000TL-L90

FEATURES

- Customizable
- 1" Aperture
- Field cuttable
- Compatible with LED strips up to 23mm (0.9 in) wide
- Durable, anodized aluminum
- Protects LEDs from dust and other elements
- Dissipates heat from LED

*LED strips sold separately



MODEL	LENGTH	LENS	FINISH
ALP2300TL	48 48 in.	FR Frosted	WH White
	96 96 in.		

ALP-2300TL

1" WIDE APERTURE TRIMLESS LED PROFILE

DIMENSIONS

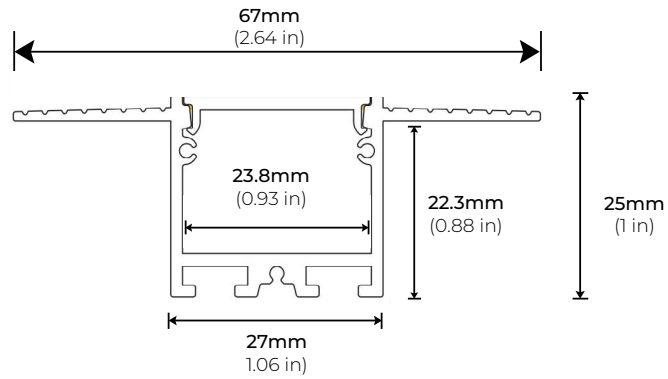

ACCESSORIES

ALP1300TL-EC
END CAP

*SOLD SEPARATELY

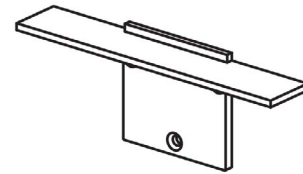

ALP2000TL-STB
STRAIGHT CONNECTOR

*SOLD SEPARATELY

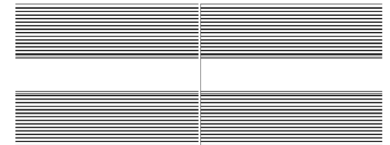
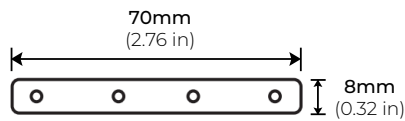

ALP2000TL-INB
INTERNAL CONNECTOR

*SOLD SEPARATELY

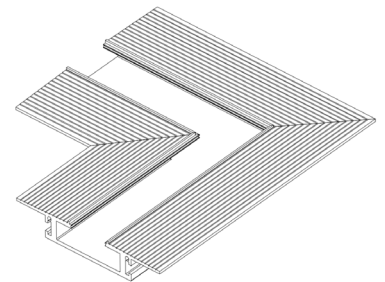
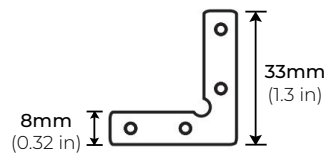

ALP2000TL-L90
RIGHT ANGLE CONNECTOR

*SOLD SEPARATELY

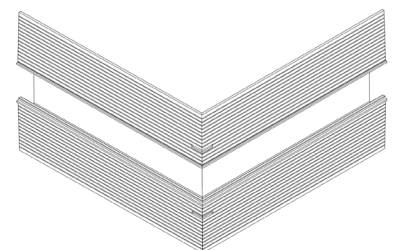
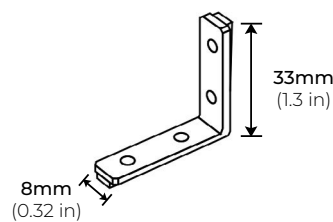

ALP-2300TL

1" WIDE APERTURE TRIMLESS LED PROFILE

ASSEMBLY

